

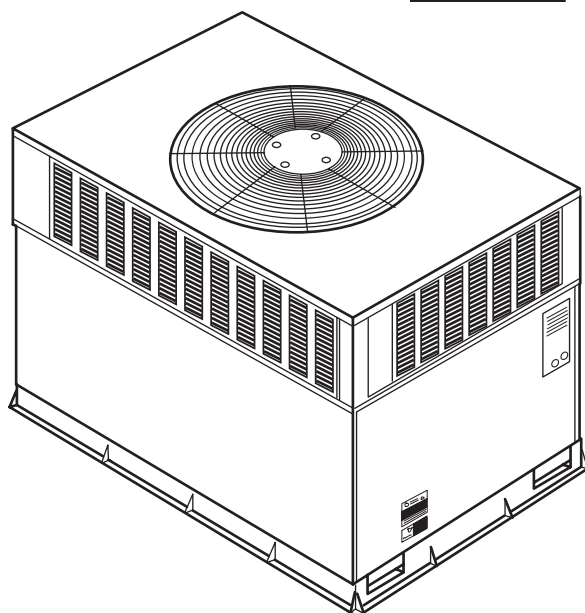

SINGLE-PACKAGED ELECTRIC COOLING UNITS with Puron® (R-410A) Refrigerant

Model 704B
Sizes 024-060
2 To 5 Nominal Tons



UNIT 704B

Single-Packaged Products with Energy-Saving Features and Puron® refrigerant.

- Low Sound Levels
- 13 SEER
- Variable Speed Blower—Standard
- Factory Installed TXV

FEATURES/BENEFITS

One-piece cooling unit with optional electric heater, low installation cost, dependable performance and easy maintenance.

EFFICIENT OPERATION

High-efficiency design with a SEER (Seasonal Energy Efficiency Ratio) of 13.0.

Puron® Environmentally Sound Refrigerant is Bryant's unique refrigerant designed to help protect the environment. Puron is an HFC refrigerant which does not contain chlorine that can harm the ozone layer. The most important advantage of Puron refrigerant is that it has not been banned in future air conditioning systems as the traditional refrigerant R-22 has been. Puron refrigerant is in service in thousands of systems proving highly reliable, environmentally sound performance.

PerfectHumidity™ Technology featuring Thermidstat control and Variable Speed Blower motor that provides greater comfort, humidity control, and energy efficiency. You can expect up to 30 times better dehumidification; economical constant fan for less than \$50 a year, which provides improved indoor air quality and more even temperatures from room to room; and reduced indoor noise due to lower air velocity. In addition, you'll realize improved installation flexibility with 3 different airflow choices for best overall comfort.

Easy Installation—Factory-assembled package is a compact, fully self-contained, electric cooling unit that is pre-wired, pre-piped, and pre-charged for minimum installation expense. 704B units are available in a variety of standard cooling sizes with voltage options to meet residential and light commercial requirements. Units are light weight, and install easily on a rooftop or at ground-level. The hightech, composite unit base eliminates rust problems associated with ground level applications.

DURABLE, DEPENDABLE COMPONENTS

Scroll Compressors are designed for high efficiency. Each compressor is hermetically sealed against contamination to help promote longer life and dependable operation. Vibration isolation provides quiet operation. Compressors have internal high-pressure and overcurrent protection.

CONVERTIBLE DUCT CONFIGURATION—Unit is designed for easy use in either downflow or horizontal applications. Each unit is easily converted from horizontal to downflow.

Direct-drive variable speed (ECM) blower motor is standard on all 704B models.

Direct-drive, PSC condenser-fan motors are designed to help reduce energy consumption and provide for cooling operation down to 55°F outdoor temperature. Motormaster® II low ambient kit is available as a field-installed accessory.

Corporate thermostats include the Time Guard® II anti-short cycle protection circuitry. If a non-Corporate thermostat without anti-short cycle protection, is used the Time Guard II field installed anti-short cycle kit is recommended.

Refrigerant system is designed to provide dependability. Liquid refrigerant filter driers are used to promote clean, unrestricted operation. Each unit leaves the factory with a full Puron® refrigerant charge. Refrigerant service connections are standard on the suction and discharge lines for checking operating pressures.

Evaporator and condenser coils are computer-designed for optimum heat transfer and cooling efficiency. The evaporator coil is fabricated from copper tube and aluminum fins and is located inside the unit for protection against damage. The condenser coil is internally mounted on the top tier of the unit. Copper fin coils and pre-coated fin coils are available from the factory by special order. These coils are recommended in applications where aluminum fins are likely to be damaged due to corrosion. They are ideal for seacoast applications.

High and Low Pressure Switches give added safety and reliability to the compressor.

Low sound ratings ensure a quiet indoor and outdoor environment with sound ratings as low as 72 dB. (See page 3.)

Easy to service cabinets provide easy single-panel accessibility to serviceable components during maintenance and installation. The unit base with integrated drain pan provides easy ground level installation with or without a mounting pad. Convenient rigging holds are provided to manipulate the unit on the jobsite. A nesting feature ensures a positive unit base to roof curb seal when the unit is roof mounted. A convenient 3/4-in. wide perimeter flange makes frame mounting on a rooftop easy.

Louvered Grille provides hail and vandalism protection for the coil.

Downflow operation is easily provided in the field to allow vertical ductwork connections. The basepan utilizes knockout style seals on the bottom openings to ensure a positive seal in the horizontal airflow mode.

Cabinets are constructed of heavy-duty, phosphated, zinc-coated prepainted steel capable of withstanding 500 hours of salt spray. Interior surfaces of the evaporator and electric heater compartments are insulated with cleanable semi-rigid insulation board, which keeps the conditioned air from being affected by the outdoor ambient temperature and provides improved indoor air quality. (Conforms to American Society of Heating, Refrigeration and Air Conditioning Engineers No. 62P.) The sloped drain pan minimizes standing water in the drain, which is provided with an external drain fitting.

Standard metal duct covers with insulation come with the unit and cover the horizontal duct openings. These can be left in place if the unit is converted to downflow.

TABLE OF CONTENTS

	Page
Features/Benefits	1,2
Model Number Nomenclature	3
ARI Capacities	3
Physical Data	4
Options and Accessories	5,6
Base Unit Dimensions	7,8
Accessory Dimensions	9
Selection Procedure	10
Performance Data	11-15
Typical Piping and Wiring	16
Application Data	17
Electrical Data	18,19
Typical Wiring Schematics	20,21
Controls	22
Guide Specifications	23,24

Model number nomenclature

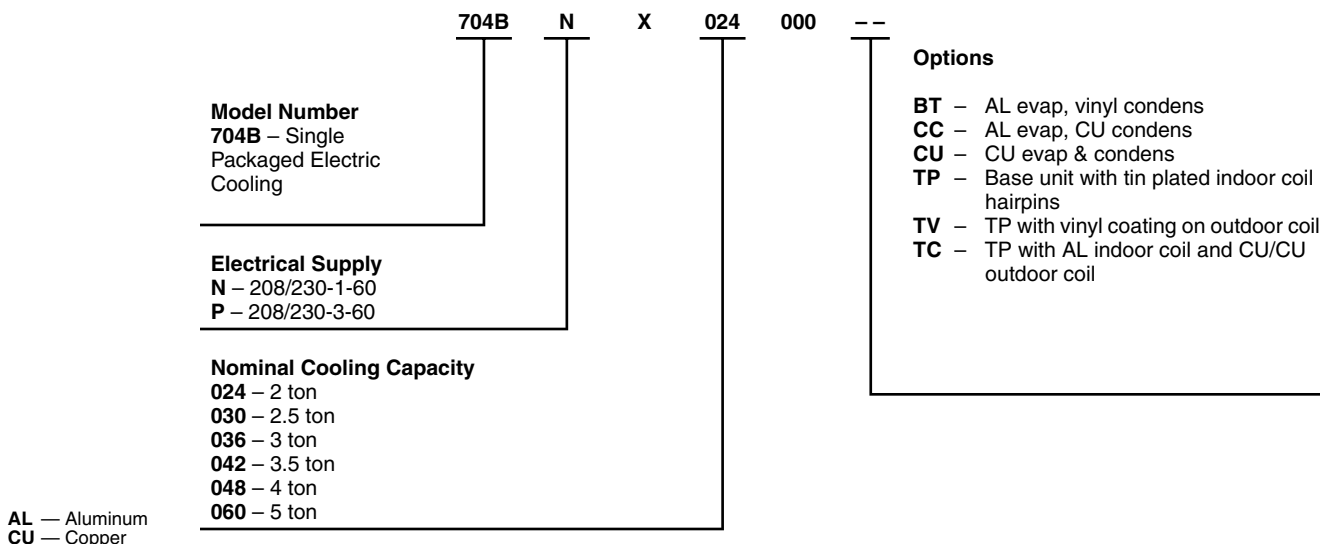

ARI* capacities

COOLING CAPACITIES AND EFFICIENCIES

UNIT 704B	NOMINAL TONS	STANDARD CFM	NET COOLING CAPACITIES (Btuh)	EER @ A**	SEER†	SOUND RATINGS‡ (dB)
024	2	800	24,000	11.0	13.0	72
030	2-1/2	1000	28,800	11.0	13.0	72
036	3	1100	36,000	11.0	13.0	72
042	3-1/2	1400	41,000	11.0	13.0	72
048	4	1450	45,000	11.0	13.0	78
060	5	1710	57,000	11.0	13.0	78

LEGEND

dB — Sound Levels (decibels)

db — Dry Bulb

SEER — Seasonal Energy Efficiency Ratio

wb — Wet Bulb

* Air Conditioning & Refrigeration Institute.

** "A" conditions – 80°F indoor db/67°F indoor wb and 95°F outdoor db.

† Rated in accordance with U.S. Government DOE Department of Energy) test procedures and/or ARI Standard 210/240-94.

‡ Tested in accordance with ARI Standard 270-95 (not listed in ARI).

NOTES:

- Ratings are net values, reflecting the effects of circulating fan heat. Ratings are based on:
Cooling Standard: 80°F db, 67°F wb indoor entering-air temperature and 95°F db outdoor entering-air temperature.
- Before purchasing this appliance, read important energy cost and efficiency information available from your retailer.

OUTDOOR SOUND: OCTAVE BAND DATA - DECIBELS

MODEL NO.	704B					
Frequency (Hz)	024	030	036	042	048	060
125	58.8	58.8	60.7	56.7	62.4	63.5
250	63.5	63.5	63.3	62.8	69.9	67.6
500	67.2	67.2	66.8	67.8	71.3	71.8
1000	66.9	66.9	66.5	67.4	73.4	75.5
2000	63.7	63.7	64.2	63.7	70.0	71.0
4000	58.3	58.3	60.3	57.7	66.3	68.1
8000	50.0	50.0	53.0	50.8	60.1	59.9

PHYSICAL DATA

UNIT SIZE 704B	024	030	036	042	048	060
NOMINAL CAPACITY (ton)	2	2-1/2	3	3-1/2	4	5
OPERATING WEIGHT (lb)	343	343	366	433	456	492
COMPRESSORS						
Quantity	Scroll					
REFRIGERANT						
REFRIGERANT (R-410A) Quantity (lb.)	7.3	8.0	9.5	10.7	11.25	13.2
REFRIGERANT METERING DEVICE						
(Indoor)	TXV	TXV	TXV	TXV	TXV	TXV
OUTDOOR COIL						
Rows—Fins/in.	2—21	2—21	2—21	2—21	2—21	2—21
Face Area (sq ft)	11.95	12.0	13.6	15.4	17.4	19.3
OUTDOOR FAN						
Nominal Airflow (Cfm)	2350	2700	2350	2800	3300	3300
Diameter	22	22	22	22	22	22
Motor Hp (Rpm)	1/8 (825)	1/8 (825)	1/8 (825)	1/8 (825)	1/4 (1100)	1/4 (1100)
OUTDOOR COIL						
Rows—Fins/in.	3—15	3—15	4—15	3—15	4—15	4—15
Face Area (sq ft)	3.7	3.7	3.7	4.7	4.7	4.7
EVAPORATOR BLOWER						
Nominal Airflow (Cfm)	800	1000	1100	1400	1400	1750
Size (in.)	10 x 10	10 x 10	10 x 10	11 x 10	11 x 10	11 x 10
Motor (Hp)	1/2	1/2	3/4	3/4	3/4	1.0
HIGH-PRESSURE SWITCH (psig)						
Cutout	610 ± 15					
Reset (Auto.)	420 ± 25					
LOSS-OF-CHARGE/LOW-PRESSURE SWITCH						
(Liquid Line) (psig)						
Cutout	20 ± 5					
Reset (Auto.)	45 ± 10					
RETURN-AIR FILTERS (In.)*						
Throwaway	20 x 20 x 1	20 x 20 x 1	20 x 24 x 1	24 x 30 x 1	24 x 30 x 1	24 x 30 x 1

* Required filter sizes shown are based on the larger of the ARI (Air Conditioning & Refrigeration Institute) rated cooling airflow or the heating airflow velocity of 300 ft/min for throwaway type or 450 ft/min for high-capacity type. Air filter pressure drop for non-standard filters must not exceed 0.08 in. wg.



OPTIONS AND ACCESSORIES

Factory-installed options

Coil options include Tin-Plated* indoor hairpins, copper/copper and vinyl-coated construction for refrigerant coils. Units are shipped standard with copper tube/aluminum fin construction. See model number nomenclature for coil options.

*Tin-Plated indoor coils are built with special hairpins that are designed to resist both general pitting corrosion and excessive indoor corrosion (Formicary Corrosion).

Field-installed accessories

Economizer with Solid-State Controls and Barometric Relief Dampers
Manual Air Damper (25% open)
Electric Heaters
Filter Rack
Flat Roof Curbs (8-in. and 14-in.)
Square-to-Round Duct Transition Kit
Thermidistat™
Thermostats
Crankcase Heater
Low Ambient Kit (Motormaster® II Control)
Solid-State Time Guard® II Device
Lifting Kit
Compressor Hard Start Kit

Economizer with solid-state controls and barometric relief dampers includes filter racks and provide outdoor air during cooling and reduce compressor operation.

Manual outside air damper includes hood and filter rack with adjustable damper blade for up to 25% outdoor air.

Electric heaters provide heat in the unit when required. Each package has a heater module that slides into the controls compartment. Heater sizes range from 5.0 to 20.0 kW. The

electric heater design allows the use of a single-point power supply for the entire unit, resulting in lower installed costs.

Flat roof curbs in both 8 in. and 14 in. sizes are available for roof mounted applications.

Square-to-round duct transition kit enables 024-048 size units to be fitted to 14 in. round ductwork.

Thermidistat Control coupled with the system's variable speed indoor blower delivers Bryant's patented PerfectHumidity™ Technology that allows for even greater humidity control. Along with more precisely controlling temperature and humidity, the Thermidistat offers full seven-day programmability allowing you to further customize your comfort and energy savings.

Thermostats provide control for the system heating and cooling functions. Thermostat models are available in both programmable and non-programmable versions.

Lifting kit, including 4 metal brackets that are available to assist in lifting this product onto a roof application.

Crankcase heater provides anti-floodback protection for low-load cooling applications.

Low-ambient kit (Motormaster II control) allows the use of mechanical cooling down to outdoor temperatures as low as 0°F.

Solid-state Time Guard II device provides short-cycling protection for the compressor. Not required with corporate electronic thermostats.

Filter rack features easy installation, serviceability, and high-filtering performance for vertical applications.

Compressor hard start kit assists compressor start-up by providing additional starting torque on single phase units and prolongs compressor motor life.

ELECTRIC HEATERS

ODS CATALOG ORDERING NO.	NOMINAL CAPACITY (kW)	USED WITH SIZES					
		024	030	036	042	048	060
ELECTRIC HEATERS (208/230 — SINGLE PHASE — 60 Hz)							
CPHEATER052A00	5.0	X	X	X	X	X	X
CPHEATER069A00	7.5	X	X	X	X	X	X
CPHEATER065A00	10.0	X	X	X	X	X	X
CPHEATER051A00	15.0		X	X	X	X	X
CPHEATER053A00	20.0			X	X	X	X
ELECTRIC HEATERS (208/230 — 3 PHASE — 60 Hz)							
CPHEATER055A00	5.0		X	X	X	X	X
CPHEATER056A00	10.0		X	X	X	X	X
CPHEATER057A00	15.0			X	X	X	X
CPHEATER059A00	20.0				X	X	X

LEGEND

ODS — Order Distribution System

NOTE: Electric heaters are rated at 240 v. Refer to Multiplication Factors table for other voltages.

MINIMUM AIRFLOW FOR RELIABLE ELECTRIC HEATER OPERATION

UNIT	024	030	036	042	048	060
AIRFLOW	750	750	1250	1205	1500	1800

ECONOMIZER

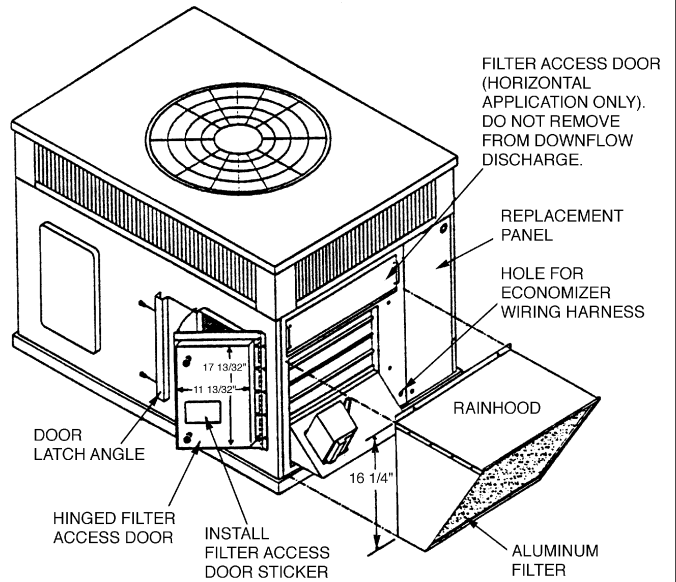
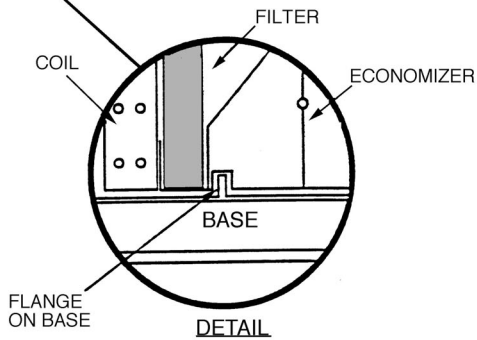
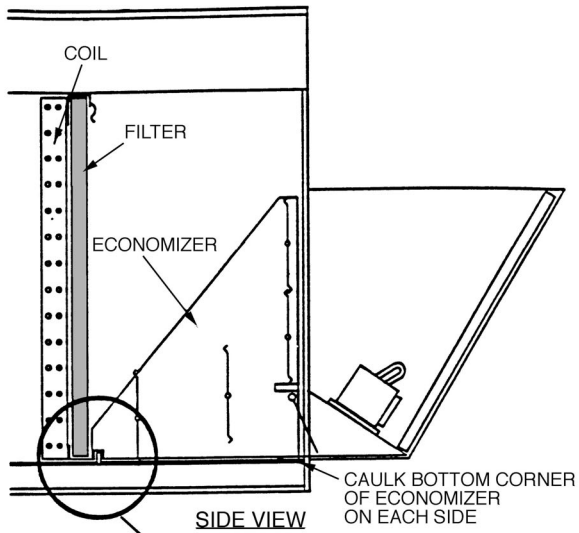

FILTER RACK

BEND FLANGE AT 90°-SCREW TO DIVIDER WITH 1-IN. SCREW

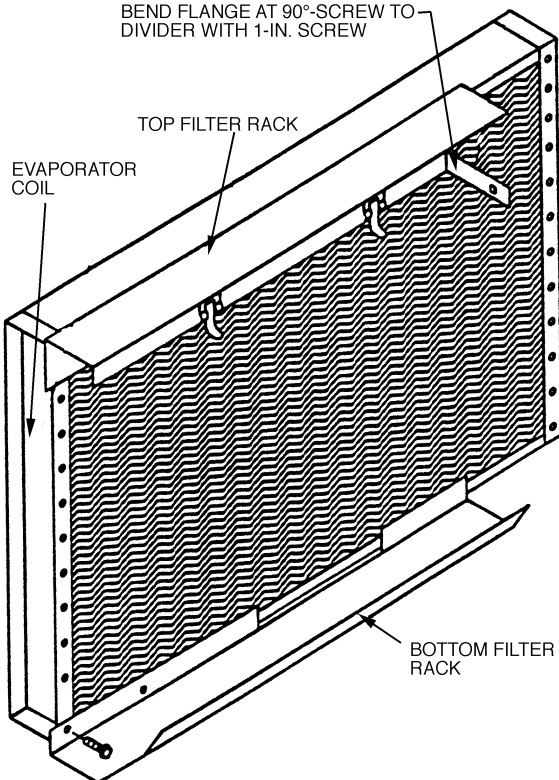

MANUAL OUTSIDE AIR DAMPER

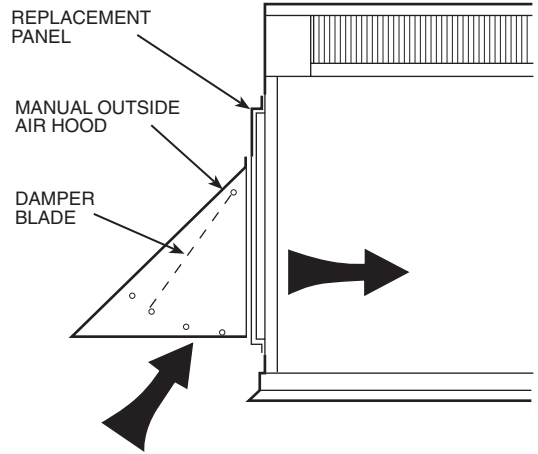

BASE UNIT DIMENSIONS — 704B024-036

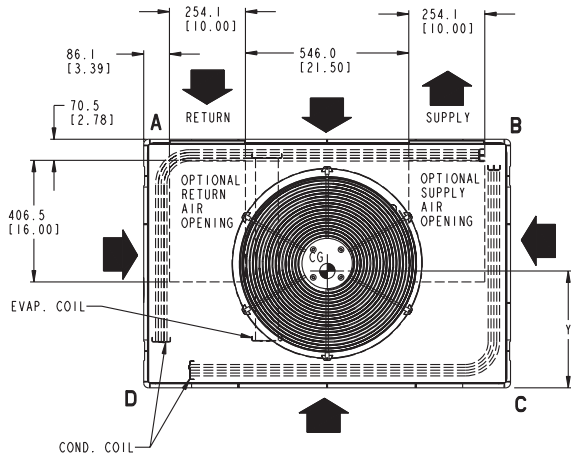

TOP VIEW

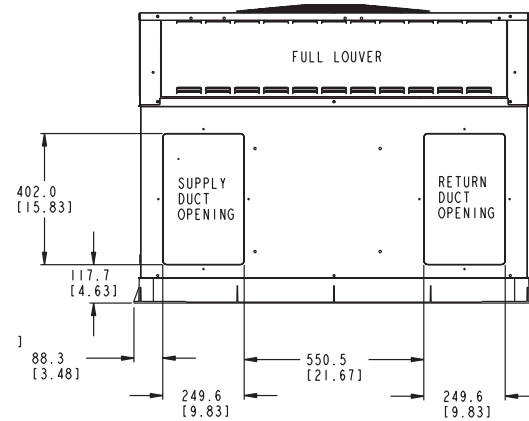

REAR VIEW

REQUIRED CLEARANCES TO COMBUSTIBLE MATL.

	MILLIMETERS [IN]
TOP OF UNIT.....	355.6 [14.00]
DUCT SIDE OF UNIT.....	50.8 [2.00]
SIDE OPPOSITE DUCTS.....	355.6 [14.00]
BOTTOM OF UNIT.....	12.7 [0.50]
ELECTRIC HEAT PANEL.....	914.4 [36.00]

NEC. REQUIRED CLEARANCES.

	MILLIMETERS [IN]
BETWEEN UNITS, POWER ENTRY SIDE.....	1066.8 [42.00]
UNIT AND UNGROUNDED SURFACES, POWER ENTRY SIDE.....	914.0 [36.00]
UNIT AND BLOCK OR CONCRETE WALLS AND OTHER GROUNDED SURFACES, POWER ENTRY SIDE.....	1066.8 [42.00]

REQUIRED CLEARANCE FOR OPERATION AND SERVICING

	MILLIMETERS [IN]
EVAP. COIL ACCESS SIDE.....	914.0 [36.00]
POWER ENTRY SIDE.....	914.0 [36.00]
(EXCEPT FOR NEC REQUIREMENTS)	
UNIT TOP.....	914.0 [36.00]
SIDE OPPOSITE DUCTS.....	914.0 [36.00]
DUCT PANEL.....	304.8 [12.00]

*MINIMUM DISTANCES: IF UNIT IS PLACED LESS THAN 304.8 [12.00] FROM WALL SYSTEM, THEN SYSTEM PERFORMANCE MAYBE COMPROMISED.

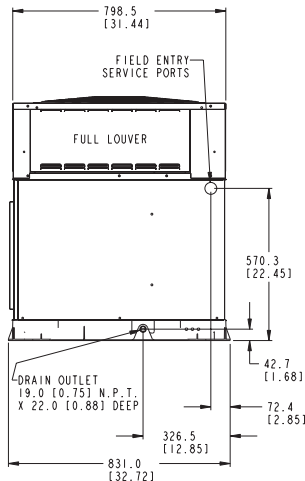

LEFT SIDE VIEW

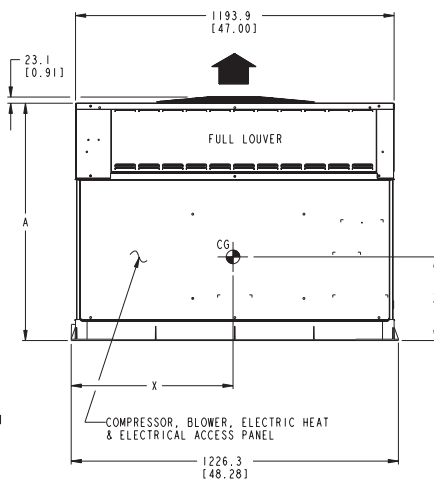

FRONT VIEW

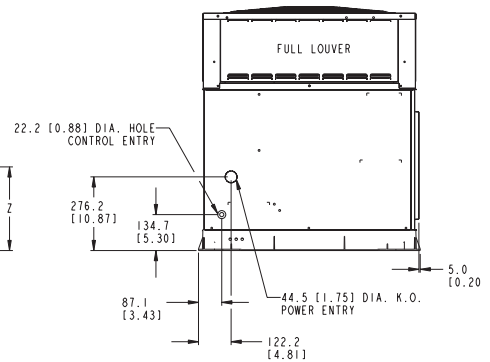

RIGHT SIDE VIEW

UNIT	ELECTRICAL CHARACTERISTICS	UNIT WEIGHT		UNIT HEIGHT in. [mm] "A"	CENTER OF GRAVITY in. [mm]		
		lb	kg		X	Y	Z
704B024	208/230-1-60	343	156	39.02 [991.1]	20 [508]	19.3 [489]	17.6 [447]
704B030	208/230-1-60	343	156	39.02 [991.1]	20 [508]	19.3 [489]	17.6 [447]
704B036	208/230-1-60, 208/230-3-60	366	166	41.02 [1041.9]	20 [508]	14 [355.6]	13 [330.2]

704B 024-036 Dimensions

BASE UNIT DIMENSIONS – 704B042-060

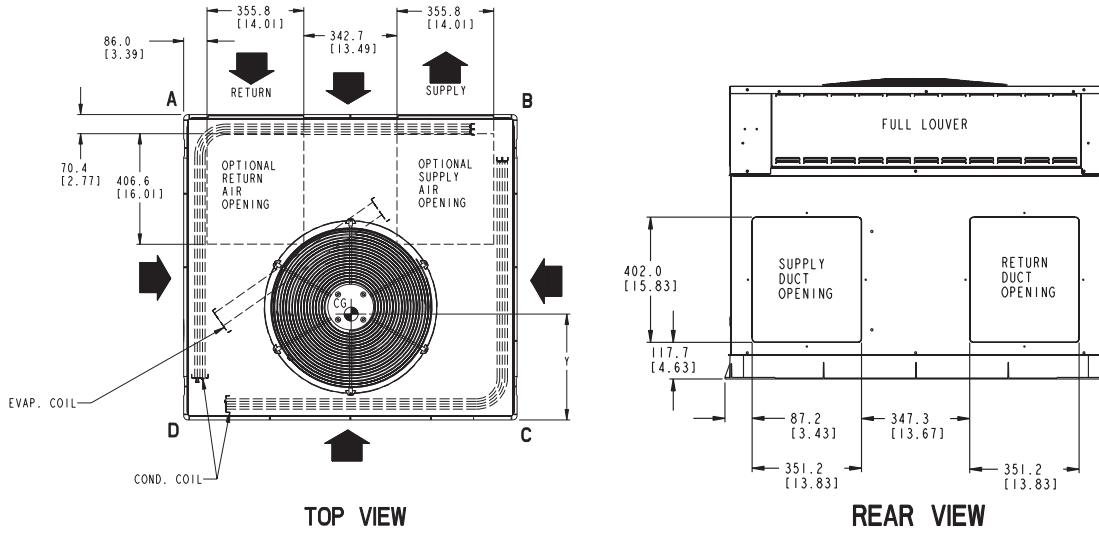

REQUIRED CLEARANCES TO COMBUSTIBLE MATL.

	MILLIMETERS [IN]
TOP OF UNIT.....	355.6 [14.00]
DUCT SIDE OF UNIT.....	50.8 [2.00]
SIDE OPPOSITE DUCTS.....	355.6 [14.00]
BOTTOM OF UNIT.....	12.7 [0.50]
ELECTRIC HEAT PANEL.....	914.4 [36.00]

NEC. REQUIRED CLEARANCES.

	MILLIMETERS [IN]
BETWEEN UNITS, POWER ENTRY SIDE.....	1066.8 [42.00]
UNIT AND UNGROUNDED SURFACES, POWER ENTRY SIDE.....	914.0 [36.00]
UNIT AND BLOCK OR CONCRETE WALLS AND OTHER GROUNDED SURFACES, POWER ENTRY SIDE.....	1066.8 [42.00]

REQUIRED CLEARANCE FOR OPERATION AND SERVICING

	MILLIMETERS [IN]
EVAP. COIL ACCESS SIDE.....	914.0 [36.00]
POWER ENTRY SIDE.....	914.0 [36.00]
(EXCEPT FOR NEC REQUIREMENTS)	
UNIT TOP.....	914.0 [36.00]
SIDE OPPOSITE DUCTS.....	914.0 [36.00]
DUCT PANEL.....	304.8 [12.00]

*MINIMUM DISTANCES: IF UNIT IS PLACED LESS THAN 304.8 [12.00] FROM WALL SYSTEM, THEN SYSTEM PERFORMANCE MAYBE COMPROMISED.

DIMENSIONS IN [] ARE IN INCHES

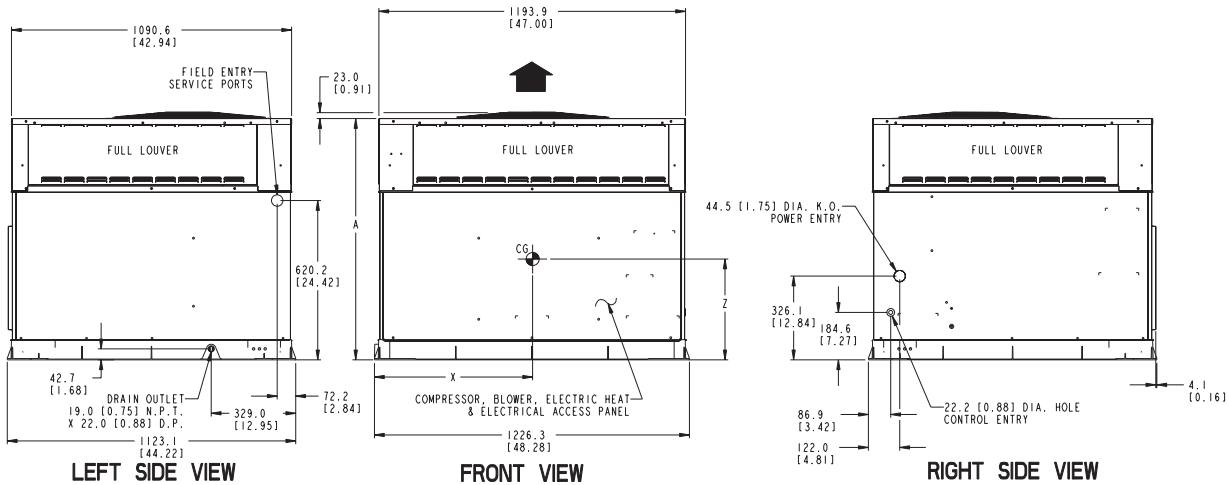

UNIT	ELECTRICAL CHARACTERISTICS	UNIT WEIGHT		UNIT HEIGHT in. [mm] "A"	CENTER OF GRAVITY in. [mm]		
		lb	kg		X	Y	Z
704B042	208/230-1-60, 208/230-3-60	433	197	42.98 [1091.7]	21 [533.4]	20.5 [520.2]	16.6 [421.6]
704B048	208-230-1-60, 208/230-3/60	456	207	44.98 [1142.5]	19.5 [495.3]	17.6 [447.6]	18.0 [457.2]
704B060	208/230-1-60, 208/230-3-60	492	223	46.98 [1193.3]	21 [533.4]	20 [508]	17.6 [447.0]

ACCESSORY DIMENSIONS

UNIT SIZE	ODS CATALOG NUMBER	A in. [mm]	B in. [mm]	C in. [mm]	D in. [mm]
704B024-036	CPRFCURB006A00	8 [203]	11 [279]	16-1/2 [419]	28-3/4 [730]
	CPRFCURB007A00	14 [356]	11 [279]	16-1/2 [419]	28-3/4 [730]
704B042-060	CPRFCURB008A00	8 [203]	16-3/16 [411]	17-3/8 [441]	40-1/4 [1022]
	CPRFCURB009A00	14 [356]	16-3/16 [411]	17-3/8 [441]	40-1/4 [1022]

NOTES:

1. Roof curb must be set up for unit being installed.
2. Seal strip must be applied, as required, to unit being installed.
3. Dimensions in [] are in millimeters.
4. Roof curb is made of 16-gage steel.
5. Table lists only the dimensions, per part number, that have changed.
6. Attach ductwork to curb (flanges of duct rest on curb).
7. Insulated panels: 1-in. thick fiberglass 1 lb density.
8. Dimensions are in inches.
9. When unit mounting screw is used (see Note A), a retainer bracket must be used as well. This bracket must also be used when required by code for hurricane or seismic conditions. This bracket is available through Micrometl.

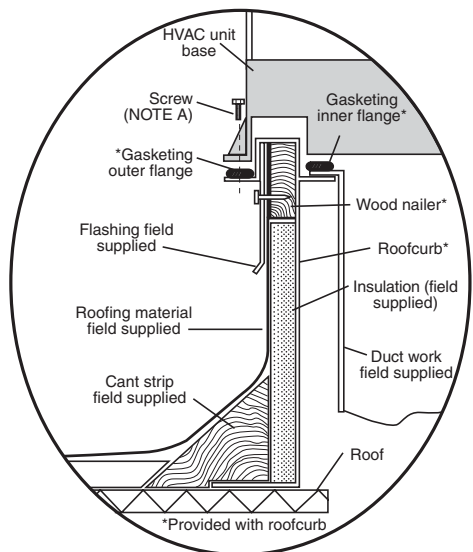

Roof Curb for Small Cabinet

Note A: When unit mounting screw is used, retainer bracket must also be used.

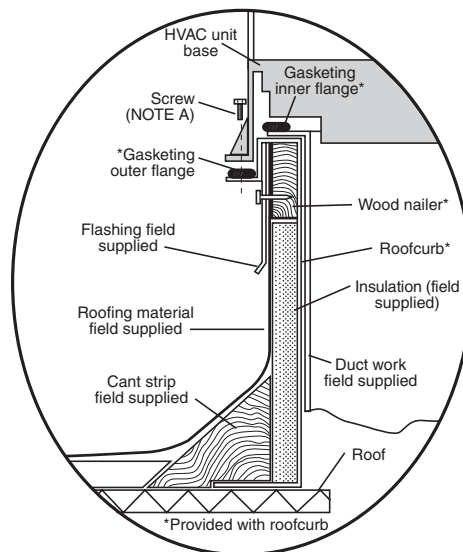

Roof Curb for Large Cabinet

Note A: When unit mounting screw is used, retainer bracket must also be used.

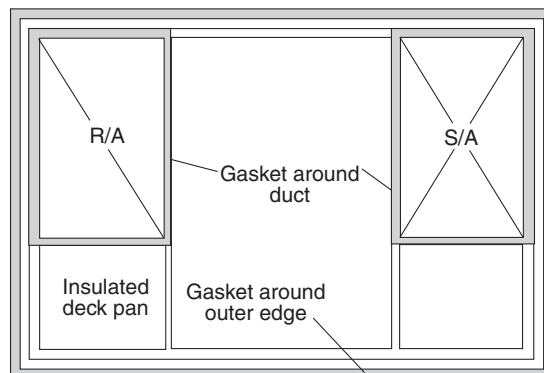
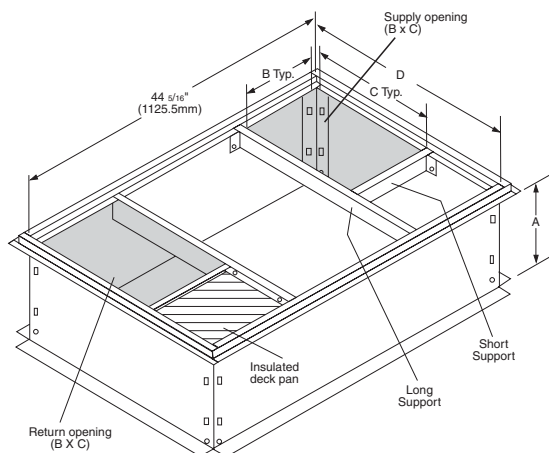

C00076

704B Corner weights (In Pounds)

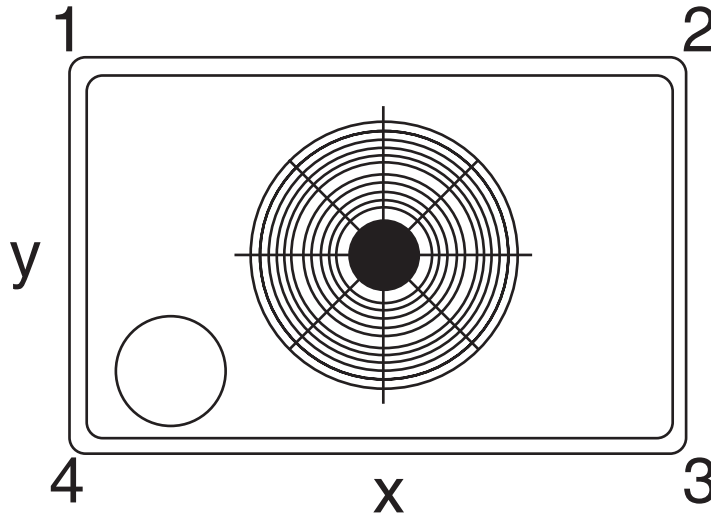

Model 704B	Small Base			Large Base		
	024	030	036	042	048	060
Corner Weight #1	69	69	74	87	92	99
Corner Weight #2	53	53	57	67	71	77
Corner Weight #3	83	83	88	104	110	119
Corner Weight #4	138	138	147	174	183	198
Total Weight	343	343	366	433	456	492

SELECTION PROCEDURE (WITH EXAMPLE)

I Determine cooling and heating requirements at design conditions:

Given:

Required Cooling Capacity (TC) 34,500 Btuh
 Sensible Heat Capacity (SHC) 26,000 Btuh
 Required Heating Capacity 15,000 Btuh
 Condenser Entering Air Temperature 95°F
 Indoor-Air Temperature 80°F edb, 67°F ewb
 Evaporator Air Quantity 1200 cfm
 External Static Pressure 0.2 in. wg
 Electrical Characteristics 230-1-60

II Select unit based on required cooling capacity.

Enter Cooling Capacities table at condenser entering temperature of 95°F. The 036 unit at 1225 cfm and 67°F ewb (entering wet bulb) will provide a total capacity of 36,500 Btuh and a SHC of 27,600 Btuh. Calculate SHC correction, if required, using Note 4 under Cooling Capacities tables.

III Select electric heat.

The required heating capacity is 15,000 Btuh (given). Determine the electric heat capacity in kW.

$$\frac{15,000 \text{ Btuh}}{3414 \text{ Btuh/kW}} = 4.4 \text{ kW of heat required}$$

Enter the Electric Heater Packages table for 208/240, single-phase, 036 unit. The 5-kW heater at 240v most

closely satisfies the heating required. To calculate kW at 208v, multiply the heater kW by multiplication factor 0.75 found in the Wattage Multiplication Factors table.

$$5 \text{ kW} \times 0.75 = 3.75 \text{ kW}$$

$$3.75 \text{ kW} \times 3414 \text{ Btuh/kW} = 12,802.50 \text{ Btuh}$$

IV Determine fan speed and power requirements at design conditions.

Before entering the air delivery tables, calculate the total static pressure required. From the given, Filter Pressure Drop table, and the Accessory Electric Heat Pressure Drop table, find:

Wet coil pressure drop	0.032 in. wg
External static pressure	0.200 in. wg
Filter	0.130 in. wg
Total static pressure	<u>0.362 in. wg</u>

Enter the table for Dry Coil Air Delivery — At 0.362 in. wg external static pressure and NOM speed pin selection, the motor delivers 1235 cfm.

V Select unit that corresponds to power source available.

The Electrical Data table shows that the unit is designed to operate at 208/230-1-60.

**PERFORMANCE DATA
STANDARD ECM INDOOR MOTOR
COOLING CAPACITIES**

704B024 COOLING PERFORMANCE TABLE													
Temp (F) Outdoor Air Entering Condenser		Evaporator Air—CFM/BF											
		800/0.026				900/0.032				1000/0.04			
		Evaporator Air — Ewb (F)											
		62	63*	67	72	62	63*	67	72	62	63*	67	72
75	TC	24.0	24.5	26.5	29.1	24.6	25.1	27.1	29.8	25.1	25.5	27.4	30.4
	SHC	21.9	21.3	18.7	15.4	23.5	22.8	19.8	16.1	25.0	24.2	20.8	16.7
	KW	1.7	1.7	1.8	1.8	1.8	1.8	1.8	1.8	1.8	1.8	1.8	1.9
85	TC	22.9	23.3	25.3	27.9	23.5	23.9	25.8	28.5	23.9	24.3	26.2	28.9
	SHC	21.4	20.7	18.1	14.9	22.9	22.2	19.2	15.6	24.3	23.6	20.3	16.2
	KW	1.9	1.9	2.0	2.0	2.0	2.0	2.0	2.0	2.0	2.0	2.1	2.1
95	TC	21.8	22.2	24.0	26.5	22.3	22.6	24.5	27.0	22.7	23.0	24.8	27.4
	SHC	20.8	20.2	17.6	14.3	22.3	21.6	18.7	15.0	23.6	22.9	19.7	15.6
	KW	2.2	2.2	2.2	2.2	2.2	2.2	2.2	2.2	2.2	2.2	2.3	2.3
105	TC	20.5	20.9	22.6	25.0	21.0	21.3	23.0	25.4	21.6	21.7	23.3	25.7
	SHC	20.2	19.5	16.9	13.7	21.6	20.9	18.0	14.3	22.5	22.2	19.0	14.9
	KW	2.4	2.4	2.4	2.4	2.4	2.4	2.5	2.5	2.5	2.5	2.5	2.5
115	TC	19.2	19.5	21.1	23.3	19.8	19.9	21.5	23.7	20.7	20.4	21.7	23.6
	SHC	19.4	18.8	16.3	13.0	20.6	20.2	17.3	13.7	21.5	21.2	18.3	14.1
	KW	2.7	2.7	2.7	2.7	2.7	2.7	2.7	2.7	2.7	2.7	2.8	2.8
125	TC	17.8	18.0	19.4	21.4	18.5	18.5	19.5	21.7	19.0	19.0	19.9	21.9
	SHC	18.5	18.1	15.5	12.3	19.2	19.2	16.5	12.9	19.8	19.7	17.6	13.5
	KW	2.9	2.9	3.0	3.0	3.0	3.0	3.0	3.0	3.0	3.0	3.1	3.1

704B030 COOLING PERFORMANCE TABLE													
Temp (F) Outdoor Air Entering Condenser		Evaporator Air—CFM/BF											
		875/0.06				1000/0.07				1125/0.08			
		Evaporator Air — Ewb (F)											
		62	63*	67	72	62	63*	67	72	62	63*	67	72
75	TC	27.9	28.6	30.7	33.6	28.8	29.4	31.6	34.5	29.3	30.0	32.2	35.2
	SHC	24.1	20.0	20.6	16.8	26.0	21.2	22.1	17.8	27.0	22.6	23.5	18.7
	KW	2.1	2.1	2.1	2.1	2.1	2.1	2.1	2.2	2.1	2.1	2.1	2.2
85	TC	26.9	27.5	29.5	32.3	27.6	28.1	30.2	33.1	28.3	28.7	30.8	33.7
	SHC	23.8	19.5	20.3	16.4	25.6	20.8	21.7	17.4	26.5	22.1	23.1	18.3
	KW	2.3	2.3	2.4	2.4	2.3	2.4	2.4	2.4	2.4	2.4	2.4	2.4
95	TC	25.6	26.2	28.2	30.8	26.3	26.8	28.8	31.5	27.0	27.3	29.3	32.0
	SHC	23.1	19.1	19.9	16.0	24.7	20.5	21.3	16.9	26.2	21.7	22.6	17.8
	KW	2.6	2.6	2.6	2.6	2.6	2.6	2.6	2.6	2.6	2.6	2.6	2.6
105	TC	24.3	24.7	26.6	29.2	25.1	25.3	27.2	29.7	25.9	25.7	27.5	30.1
	SHC	22.4	18.6	19.3	15.4	23.8	19.9	20.8	16.3	24.4	21.1	22.1	17.2
	KW	2.9	2.9	2.9	2.9	2.9	2.9	2.9	2.9	2.9	2.9	2.9	2.9
115	TC	22.8	23.2	24.9	27.3	23.8	23.6	25.3	27.7	24.5	24.0	25.7	28.1
	SHC	21.7	18.0	18.8	14.8	22.3	19.3	20.2	15.7	23.7	20.5	21.5	16.6
	KW	3.2	3.2	3.2	3.2	3.2	3.2	3.2	3.2	3.2	3.2	3.2	3.2
125	TC	21.4	21.4	24.9	27.3	23.8	23.6	25.3	27.7	24.5	24.0	25.7	28.1
	SHC	20.7	17.3	18.8	14.8	22.3	19.3	20.2	15.7	23.7	20.5	21.5	16.6
	KW	3.5	3.5	3.2	3.2	3.2	3.2	3.2	3.2	3.2	3.2	3.2	3.2

**PERFORMANCE DATA
STANDARD ECM INDOOR MOTOR
COOLING CAPACITIES**

704B036 COOLING PERFORMANCE TABLE													
Temp (F) Outdoor Air Entering Condenser		Evaporator Air—CFM/BF											
		1100/0.06				1225/0.07				1400/0.08			
		Evaporator Air — Ewb (F)											
		62	63*	67	72	62	63*	67	72	62	63*	67	72
75	TC	36.2	36.8	39.7	43.8	36.9	37.4	40.3	44.4	37.9	38.1	41.0	45.1
	SHC	33.2	26.7	27.8	22.3	34.7	27.9	29.0	23.1	36.9	29.6	30.9	24.2
	KW	2.7	2.7	2.7	2.7	2.7	2.7	2.7	2.8	2.8	2.8	2.8	2.9
85	TC	34.6	35.1	37.9	41.8	35.3	35.6	38.4	42.4	36.4	36.3	39.1	43.1
	SHC	32.4	26.0	27.1	21.6	34.0	27.1	28.3	22.4	35.6	28.9	30.2	23.6
	KW	2.9	2.9	3.0	3.0	3.0	3.0	3.0	3.0	3.1	3.1	3.1	3.2
95	TC	33.0	33.4	36.0	39.7	33.7	33.8	36.5	40.2	34.8	34.4	37.0	40.8
	SHC	31.6	25.3	26.4	20.9	32.9	26.4	27.6	21.7	34.4	28.1	29.4	22.8
	KW	3.2	3.2	3.3	3.3	3.3	3.3	3.3	3.4	3.4	3.4	3.4	3.5
105	TC	31.3	31.5	34.0	37.5	32.1	31.9	34.3	37.9	33.1	32.4	34.9	38.4
	SHC	30.6	24.5	25.6	20.1	31.5	25.7	26.8	20.9	32.8	27.3	28.6	22.0
	KW	3.6	3.6	3.6	3.6	3.6	3.6	3.7	3.7	3.8	3.7	3.8	3.8
115	TC	29.6	29.4	31.8	35.0	30.4	29.8	32.1	35.4	31.3	30.3	32.6	35.8
	SHC	29.3	23.7	24.8	19.3	30.0	24.8	26.0	20.0	31.0	26.4	27.7	21.1
	KW	4.0	4.0	4.0	4.0	4.0	4.0	4.0	4.0	4.1	4.1	4.1	4.2
125	TC	27.8	27.2	29.4	32.4	28.4	27.5	29.7	32.7	29.3	28.0	30.1	33.0
	SHC	27.5	22.8	23.9	18.4	28.2	23.8	25.0	19.1	29.0	25.4	26.7	20.2
	KW	4.4	4.3	4.4	4.4	4.4	4.4	4.4	4.4	4.5	4.5	4.5	4.5

704B042 COOLING PERFORMANCE TABLE													
Temp (F) Outdoor Air Entering Condenser		Evaporator Air—CFM/BF											
		1100/0.06				1225/0.07				1400/0.08			
		Evaporator Air — Ewb (F)											
		62	63*	67	72	62	63*	67	72	62	63*	67	72
75	TC	39.6	40.4	43.4	47.6	40.5	41.2	44.2	48.4	41.5	42.1	45.1	49.4
	SHC	33.5	27.6	28.6	23.4	35.4	29.0	30.0	24.3	37.9	30.8	31.9	25.6
	KW	3.0	3.0	3.0	3.1	3.0	3.0	3.0	3.0	3.1	3.0	3.0	3.1
85	TC	37.9	38.7	41.5	45.5	38.7	39.4	42.3	46.3	39.7	40.2	43.2	47.2
	SHC	32.8	26.9	27.8	22.7	34.6	28.2	29.2	23.6	37.0	30.0	31.1	24.8
	KW	3.3	3.3	3.4	3.4	3.3	3.3	3.4	3.4	3.3	3.3	3.4	3.4
95	TC	36.2	36.8	39.6	43.4	36.9	37.5	40.3	44.1	37.8	38.2	41.0	44.9
	SHC	32.0	26.1	27.0	21.9	33.8	27.4	28.4	22.8	35.9	29.1	30.3	24.0
	KW	3.7	3.7	3.7	3.8	3.7	3.7	3.7	3.8	3.7	3.7	3.7	3.8
105	TC	34.2	34.8	37.4	41.0	34.9	35.4	38.0	41.6	36.0	36.0	38.7	42.3
	SHC	31.0	25.2	26.2	21.1	32.7	26.5	27.6	22.0	34.3	28.3	29.4	23.2
	KW	4.1	4.1	4.1	4.1	4.1	4.1	4.1	4.1	4.1	4.1	4.1	4.1
115	TC	32.1	32.6	35.0	38.4	32.8	33.1	35.5	38.9	34.0	33.7	36.1	39.5
	SHC	30.0	24.3	25.2	20.2	31.4	25.6	26.6	21.0	32.8	27.3	28.5	22.2
	KW	4.5	4.5	4.5	4.5	4.5	4.5	4.5	4.6	4.5	4.5	4.5	4.6
125	TC	29.8	30.1	32.3	35.3	30.6	30.5	32.7	35.7	31.7	31.0	33.2	36.2
	SHC	28.6	23.2	24.2	19.1	29.6	24.5	25.5	20.0	30.6	26.1	27.3	21.1
	KW	4.9	4.9	4.9	5.0	4.9	4.9	4.9	5.0	4.9	4.9	4.9	5.0

See Legend and Notes on page 13.

**PERFORMANCE DATA
STANDARD ECM INDOOR MOTOR
COOLING CAPACITIES**

704B048 COOLING PERFORMANCE TABLE													
Temp (F) Outdoor Air Entering Condenser		Evaporator Air—CFM/BF											
		1260/0.06				1400/0.06				1600/0.08			
		Evaporator Air — Ewb (F)											
		62	63*	67	72	62	63*	67	72	62	63*	67	72
75	TC	45.0	45.8	49.6	54.7	46.7	47.3	51.2	56.3	48.1	48.7	52.5	57.8
	SHC	39.3	32.0	33.4	27.2	42.6	34.3	35.8	28.9	45.8	36.8	38.4	30.6
	KW	3.4	3.4	3.4	3.4	3.4	3.4	3.4	3.5	3.4	3.4	3.4	3.5
85	TC	42.8	43.6	47.2	52.1	44.3	44.9	48.6	53.5	45.6	46.1	49.9	54.8
	SHC	38.2	30.9	32.3	26.2	41.3	33.2	34.7	27.7	44.3	35.5	37.3	29.4
	KW	3.7	3.7	3.8	3.8	3.7	3.7	3.8	3.8	3.8	3.8	3.8	3.8
95	TC	40.6	41.3	44.7	49.4	41.8	42.4	46.0	50.7	44.2	43.7	47.0	51.8
	SHC	36.9	29.8	31.2	25.2	39.9	32.0	33.6	26.7	43.0	34.6	36.1	28.3
	KW	4.1	4.1	4.2	4.2	4.1	4.1	4.2	4.2	4.2	4.1	4.2	4.2
105	TC	38.2	38.9	42.1	46.4	39.6	39.8	43.1	47.6	41.5	40.8	44.0	48.5
	SHC	35.7	28.7	30.1	24.0	38.3	30.7	32.3	25.5	40.0	33.2	34.8	27.0
	KW	4.6	4.6	4.6	4.6	4.6	4.6	4.6	4.7	4.6	4.6	4.6	4.7
115	TC	35.7	36.3	39.3	43.3	38.2	37.1	40.1	44.2	38.7	37.9	40.8	45.0
	SHC	34.4	27.5	28.9	22.9	35.7	29.5	31.0	24.3	38.2	31.8	33.5	25.8
	KW	5.0	5.0	5.1	5.1	5.1	5.0	5.1	5.1	5.1	5.1	5.1	5.1
125	TC	33.4	33.4	36.2	39.4	34.6	34.1	36.9	40.5	36.1	34.8	37.5	41.2
	SHC	32.1	26.2	27.6	21.5	33.8	28.2	29.7	22.9	35.6	30.2	31.9	24.4
	KW	5.6	5.6	5.6	5.7	5.6	5.6	5.6	5.6	5.6	5.6	5.6	5.6

704B060 COOLING PERFORMANCE TABLE													
Temp (F) Outdoor Air Entering Condenser		Evaporator Air—CFM/BF											
		1500/0.004				1750/0.007				2000/0.01			
		Evaporator Air — Ewb (F)											
		62	63*	67	72	62	63*	67	72	62	63*	67	72
75	TC	57.2	58.2	62.4	68.1	58.8	59.7	64.0	69.8	60.0	60.8	64.9	70.8
	SHC	49.4	47.9	41.6	33.8	53.6	51.8	44.5	35.4	57.6	55.4	47.1	36.8
	KW	4.1	4.1	4.2	4.2	4.2	4.3	4.3	4.4	4.4	4.4	4.5	4.6
85	TC	54.7	55.6	59.7	65.2	56.2	57.0	61.1	66.6	57.4	58.1	61.9	67.4
	SHC	48.2	46.7	40.4	32.6	52.4	50.5	43.2	34.2	56.3	54.2	45.8	35.6
	KW	4.5	4.5	4.6	4.7	4.7	4.7	4.8	4.9	4.8	4.9	5.0	5.0
95	TC	52.2	53.0	56.9	62.0	53.5	54.3	58.0	63.2	55.0	55.3	58.7	64.1
	SHC	47.0	45.4	39.2	31.4	51.1	49.2	41.9	32.9	55.0	52.9	44.5	34.4
	KW	5.0	5.0	5.1	5.2	5.1	5.2	5.3	5.3	5.2	5.3	5.5	5.5
105	TC	49.4	50.2	53.8	58.7	50.7	51.4	54.8	59.6	52.5	52.4	55.4	60.2
	SHC	45.7	44.1	37.9	30.1	49.8	47.9	40.6	31.6	52.5	51.6	43.2	33.0
	KW	5.5	5.6	5.6	5.7	5.7	5.7	5.8	5.9	5.8	5.8	6.0	6.1
115	TC	46.5	47.2	50.5	55.0	48.1	48.3	51.3	56.8	49.7	49.7	51.8	57.0
	SHC	44.3	42.7	36.4	28.7	48.1	46.6	39.2	30.6	49.7	49.7	41.8	31.7
	KW	6.1	6.2	6.2	6.3	6.2	6.3	6.4	6.4	6.4	6.4	6.6	6.6
125	TC	43.3	43.9	46.7	52.2	45.2	45.1	47.4	52.5	46.4	46.4	47.9	52.2
	SHC	42.8	41.2	34.9	27.8	45.2	45.1	37.6	28.9	46.4	46.4	40.2	29.7
	KW	6.7	6.8	6.8	6.8	6.8	6.9	7.0	7.0	7.0	7.0	7.2	7.2

LEGEND

- BF** — Bypass Factor
- Ewb** — Entering Wet-Bulb
- kW** — Total Unit Power Input
- SHC** — Sensible Heat Capacity (1000 Btuh)
- TC** — Cooling Capacity (1000 Btuh)
- ECM** — Electronic Computed Motor
- *** — TVA Conditions (75°F Entering Dry Bulb)

$$t_{ldb} = t_{edb} - \frac{\text{sensible capacity (Btuh)}}{1.10 \times \text{cfm}}$$

$$t_{lwb} = \text{Wet-bulb temperature corresponding to enthalpy of air leaving evaporator coil } (h_{lwb})$$

$$h_{lwb} = h_{ewb} - \frac{\text{total capacity (Btuh)}}{4.5 \times \text{cfm}}$$

Where: h_{ewb} = Enthalpy of air entering evaporator coil

NOTES:

1. Ratings are net; they do account for the effects of the evaporator-fan motor power and heat.
2. Direct interpolation is permissible. Do not extrapolate.
3. The following formulas may be used:
4. The SHC is based on 80°F Edb (Entering dry bulb) air temperature through Evaporator coil. Below 80°F Edb, subtract (Correction Factor x CFM) from SHC. Above 80°F Edb, add (Correction Factor x CFM) to SHC. Correction Factor = $1.10 \times (1 - BF) \times (Edb - 8)$

PERFORMANCE DATA (CONT)

ECONOMIZER 1-in. FILTER PRESSURE DROP (in. wg)

UNIT 704B	PRESSURE DROP
024-036	0.20
042-060	0.25

MULTIPLICATION FACTORS

HEATER kW RATING	VOLTAGE DISTRIBUTION	MULTIPLICATION FACTOR
240	200	.69
	208	.75
	230	.92
	240	1.00

Example: 20 kW (at 240v) heater on 230v
 = 20.0 (.92 mult factor)
 = 18.4 kW capacity at 230 v

FILTER PRESSURE DROP (In. wg)

FILTER SIZE	CFM																			
	500	600	700	800	900	1000	1100	1200	1300	1400	1500	1600	1700	1800	1900	2000	2100	2200	2300	
20 X 20 X 1	0.05	0.07	0.08	0.10	0.12	0.13	0.14	0.15	—	—	—	—	—	—	—	—	—	—	—	—
20 X 24 X 1	—	—	—	—	0.09	0.10	0.11	0.13	0.14	0.15	0.16	—	—	—	—	—	—	—	—	—
24 X 30 X 1	—	—	—	—	—	—	—	0.07	0.08	0.09	0.10	0.11	0.12	0.13	0.14	0.15	0.16	0.17	0.18	—

ELECTRIC HEAT PRESSURE DROP TABLES

Small Cabinet: 024-036

STATIC	CFM											
	500	600	700	800	900	1000	1100	1200	1300	1400	1500	1600
5 Kw	0.00	0.00	0.00	0.00	0.00	0.00	0.00	0.00	0.02	0.04	0.06	0.07
7.5 Kw	0.00	0.00	0.00	0.00	0.00	0.00	0.02	0.03	0.05	0.07	0.08	0.09
10 Kw	0.00	0.00	0.00	0.00	0.00	0.02	0.04	0.06	0.07	0.09	0.10	0.11
15 Kw	0.00	0.00	0.00	0.02	0.04	0.06	0.08	0.10	0.12	0.14	0.16	0.18

Large Cabinet: 042-060

STATIC	CFM														
	1100	1200	1300	1400	1500	1600	1700	1800	1900	2000	2100	2200	2300	2400	2500
5 Kw	0.00	0.00	0.00	0.01	0.02	0.03	0.04	0.05	0.06	0.07	0.08	0.09	0.10	0.11	0.12
7.5 Kw	0.00	0.00	0.01	0.02	0.03	0.04	0.05	0.06	0.07	0.08	0.09	0.10	0.11	0.12	0.13
10 Kw	0.00	0.00	0.01	0.02	0.03	0.04	0.05	0.06	0.07	0.08	0.09	0.10	0.11	0.12	0.13
15 Kw	0.00	0.02	0.03	0.04	0.05	0.06	0.07	0.08	0.09	0.10	0.11	0.12	0.13	0.14	0.15
20 Kw	0.02	0.03	0.04	0.05	0.06	0.07	0.08	0.09	0.10	0.11	0.12	0.13	0.14	0.15	0.16

704B ECM DRY COIL AIRFLOW—SMALL CABINET

UNIT SIZE	CFM ADJUST PIN SELECT	LO PIN			NOM PIN			HI PIN		
	EXTERNAL STATIC PRESSURE RANGE	0.0–0.39	0.4–0.69	0.7–1.0	0.0–0.39	0.4–0.69	0.7–1.0	0.0–0.39	0.4–0.69	0.7–1.0
024	COOLING	800	725	—	885	805	730	990	930	855
	COOLING DEHUMIDIFY	715	670	—	715	695	645	795	775	745
030	COOLING	1010	920	825	1105	1030	930	1255	1160	1050
	COOLING DEHUMIDIFY	890	845	795	890	865	825	1010	980	925
036	COOLING	1110	1025	970	1235	1175	1115	1400	1355	1280
	COOLING DEHUMIDIFY	990	960	910	990	975	940	1125	1110	1085

704B ECM DRY COIL AIRFLOW—LARGE CABINET

UNIT SIZE	CFM ADJUST PIN SELECT	LO PIN	NOM PIN	HI PIN
	EXTERNAL STATIC PRESSURE RANGE	0.1–1.0	0.1–1.0	0.1–1.0
042	COOLING	1100	1225	1410
	COOLING DEHUMIDIFY	980	980	1125
048	COOLING	1260	1400	1610
	COOLING DEHUMIDIFY	1120	1120	1290
060	COOLING	1575	1750	2010
	COOLING DEHUMIDIFY	1400	1400	1610

704B ECM WET COIL PRESSURE DROP

UNIT SIZE	STANDARD CFM															
	600	700	800	900	1000	1100	1200	1300	1400	1500	1600	1700	1800	1900	2000	2100
024	0.005	0.007	0.010	0.012	0.015	—	—	—	—	—	—	—	—	—	—	—
030	—	0.007	0.010	0.012	0.015	0.018	0.021	0.024	—	—	—	—	—	—	—	—
036	—	—	—	0.019	0.023	0.027	0.032	0.037	0.042	0.047	—	—	—	—	—	—
042	—	—	—	—	0.014	0.017	0.020	0.024	0.027	0.031	0.035	0.039	0.043	—	—	—
048	—	—	—	—	—	—	0.027	0.032	0.036	0.041	0.046	0.052	0.057	0.063	0.068	—
060	—	—	—	—	—	—	—	—	—	0.029	0.032	0.036	0.040	0.045	0.049	0.053

TYPICAL PIPING AND WIRING

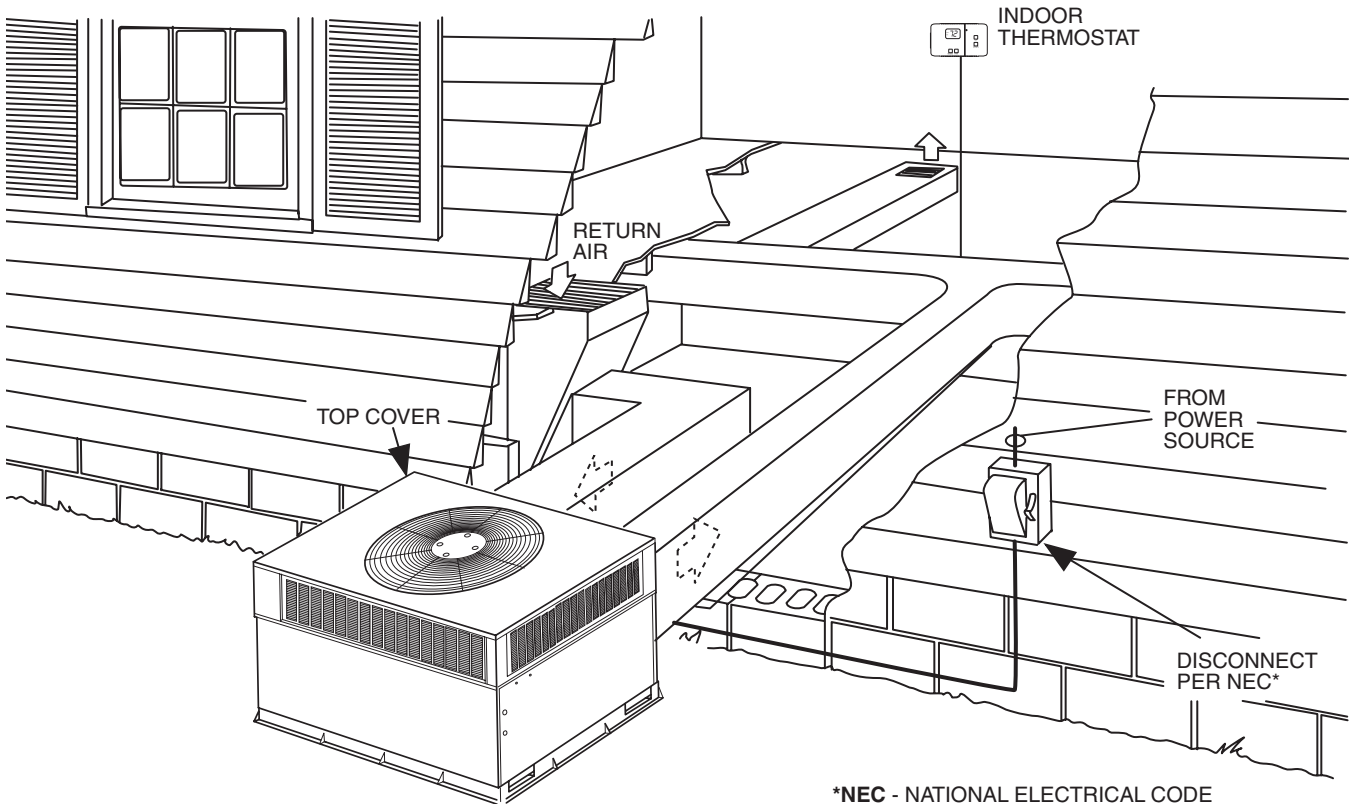
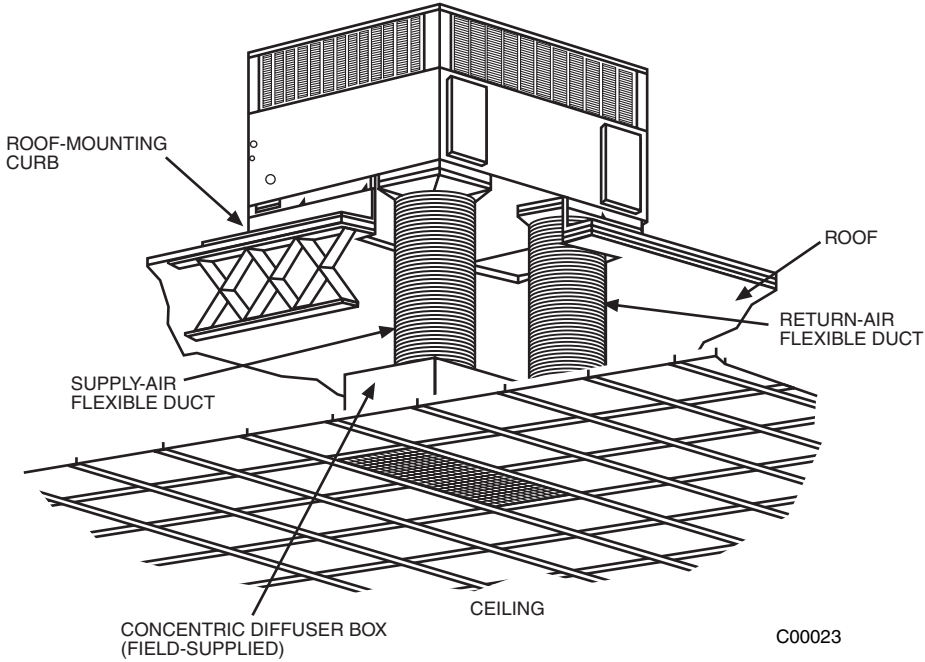

C00063

APPLICATION DATA

Condensate trap — A 2-in. condensate trap must be field supplied.

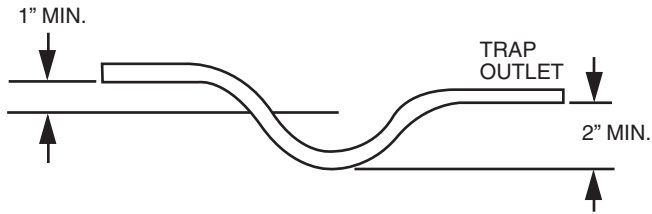

Ductwork — Secure downflow discharge ductwork to roof curb. For horizontal discharge applications, attach ductwork to unit with flanges.

To convert a unit to downflow discharge — Units are equipped with factory-installed inserts in the downflow openings.

Remove the inserts similar to removing an electrical knock-out. Leave on duct covers to seal the horizontal discharge openings in the unit. Units installed in horizontal discharge orientation do not require duct covers.

Maximum cooling airflow — To minimize the possibility of condensate blow-off from the evaporator, airflow through the units should not exceed 450 cfm/ton.

Minimum cooling airflow — The minimum airflow is 350 cfm/ton for cooling mode. Airflow can be lower in certain modes when humidity removal is an issue.

Minimum cooling operating air temperature — All standard units have a minimum ambient operating temperature of 55°F. With accessory low ambient temperature kit, units can operate at temperatures down to 0°F.

Maximum cooling operating outdoor air temperature — Maximum outdoor operating air temperature for cooling is 125°F.

ELECTRICAL DATA

UNIT SIZE 704B	V-PH-Hz	VOLTAGE RANGE		COMPRESSOR		OUTDOOR FAN MOTOR	INDOOR FAN MOTOR	ELECTRIC HEAT		POWER SUPPLY		
		Min	Max	RLA	LRA	FLA	FLA	Nominal kW*	FLA	UNIT MCA	MAX FUSE or CKT. BKR.	MOCP
024	208/230-1-60	187	253	13.5	61.0	0.8	4.3	—/—	—/—	22.0/22.0	30/30	—
								3.8/5	18.1/20.8	27.9/31.4	30/35	—
								5.4/7.2	26/30	37.9/42.9	40/45	—
030	208/230-1-60	187	253	15.9	73.0	0.8	4.3	—/—	—/—	25.0/25.0	30/30	—
								3.8/5	18.1/20.8	27.9/31.4	30/35	—
								5.4/7.2	26/30	37.9/42.9	40/45	—
036	208/230-1-60	187	253	16.9	83.0	0.8	6.8	—/—	—/—	28.7/28.7	35/35	—
								3.8/5	18.1/20.8	31.1/34.5	35/40	—
								5.4/7.2	26/30	41.0/46.0	45/50	—
036	208/230-3-60	187	253	12.2	77.0	0.8	6.8	—/—	—/—	22.9/22.9	30/30	—
								5	10.4/12	22.9/23.5	30/30	—
								10	20.8/24.1	34.6/38.6	40/40	—
042	208/230-1-60	187	253	22.4	105.0	0.8	6.8	—/—	—/—	35.6/35.6	45/45	—
								3.8/5	18.1/20.8	35.6/35.6	45/45	—
								5.4/7.2	26/30	41.0/46.0	45/50	—
042	208/230-3-60	187	253	15.4	88.0	0.8	6.8	—/—	—/—	26.9/26.9	35/35	—
								7.5/10	36.1/41.7	53.6/60.6	—	60/70
								11.3/15	54.2/62.5	76.2/86.6	—	80/90
048	208/230-1-60	187	253	21.3	109.0	1.6	6.8	—/—	—/—	35.0/35.0	45/45	—
								3.8/5	18.1/20.8	35.0/35.0	45/45	—
								5.4/7.2	26/30	41.0/46.0	45/50	—
048	208/230-3-60	187	253	14.7	91.0	1.6	6.8	—/—	—/—	26.8/26.8	35/35	—
								7.5/10	36.1/41.7	53.6/60.6	—	60/70
								11.3/15	54.2/62.5	76.2/86.6	—	80/90
060	208/230-1-60	187	253	27.0	145.0	1.6	9.1	—/—	—/—	44.5/44.5	60/60	—
								3.8/5	18.1/20.8	44.5/44.5	60/60	—
								5.4/7.2	26/30	44.5/48.9	60/60	—
060	208/230-3-60	187	253	19.2	137.0	1.6	9.1	—/—	—/—	34.7/34.7	40/40	—
								7.5/10	36.1/41.7	56.5/63.5	—	60/70
								11.3/15	54.2/62.5	79.1/89.5	—	80/90
060	208/230-3-60	187	253	19.2	137.0	1.6	9.1	—/—	—/—	101.6/115.5	—	100/125
								3.8/5	10.4/12	34.7/34.7	40/40	—
								7.5/10	20.8/24.1	37.4/41.4	45/45	—
060	208/230-3-60	187	253	19.2	137.0	1.6	9.1	—/—	—/—	60.5/68.5	—	70/70
								11.3/15	31.3/36.1	50.5/56.5	60/60	—
								15/19.94	41.6/48	63.3/71.3	—	70/80

*See Legend and Notes on page 19.

ELECTRICAL DATA LEGEND

LEGEND

- FLA — Full Load Amps
 LRA — Locked Rotor Amps
 MCA — Minimum Circuit Amps
 MOCP — Maximum Overcurrent Protection
 RLA — Rated Load Amps



*Heater capacity (KW) based on heater voltage of 208v, 240v, & 480v.
 If power distribution voltage to unit varies from rated heater voltage,
 heater KW will vary accordingly.

NOTES:

- In compliance with NEC (National Electrical Code) requirements for multimotor and combination load equipment (refer to NEC Articles 430 and 440), the overcurrent protective device for the unit shall be Power Supply fuse. The CGA (Canadian Gas Association) units may be fuse or circuit breaker.
- Minimum wire size is based on 60 C copper wire. If other than 60 C wire is used, or if length exceeds wire length in table, determine size from NEC.
- Unbalanced 3-Phase Supply Voltage
Never operate a motor where a phase imbalance in supply voltage is greater than 2%. Use the following formula to determine the percentage of voltage imbalance.

% Voltage imbalance

$$= 100 \times \frac{\text{max voltage deviation from average voltage}}{\text{average voltage}}$$

EXAMPLE: Supply voltage is 460-3-60.

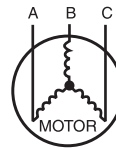

AB = 452 v
 BC = 464 v
 AC = 455 v

$$\begin{aligned} \text{Average Voltage} &= \frac{452 + 464 + 455}{3} \\ &= \frac{1371}{3} \\ &= 457 \end{aligned}$$

Determine maximum deviation from average voltage.

(AB) 457 - 452 = 5 v
 (BC) 464 - 457 = 7 v
 (AC) 457 - 455 = 2 v

Maximum deviation is 7 v.

Determine percent of voltage imbalance.

$$\begin{aligned} \% \text{ Voltage Imbalance} &= 100 \times \frac{7}{457} \\ &= 1.53\% \end{aligned}$$

This amount of phase imbalance is satisfactory as it is below the maximum allowable 2%.

IMPORTANT: If the supply voltage phase imbalance is more than 2%, contact your local electric utility company immediately.

TYPICAL WIRING SCHEMATIC — 208-230-3-60 SHOWN

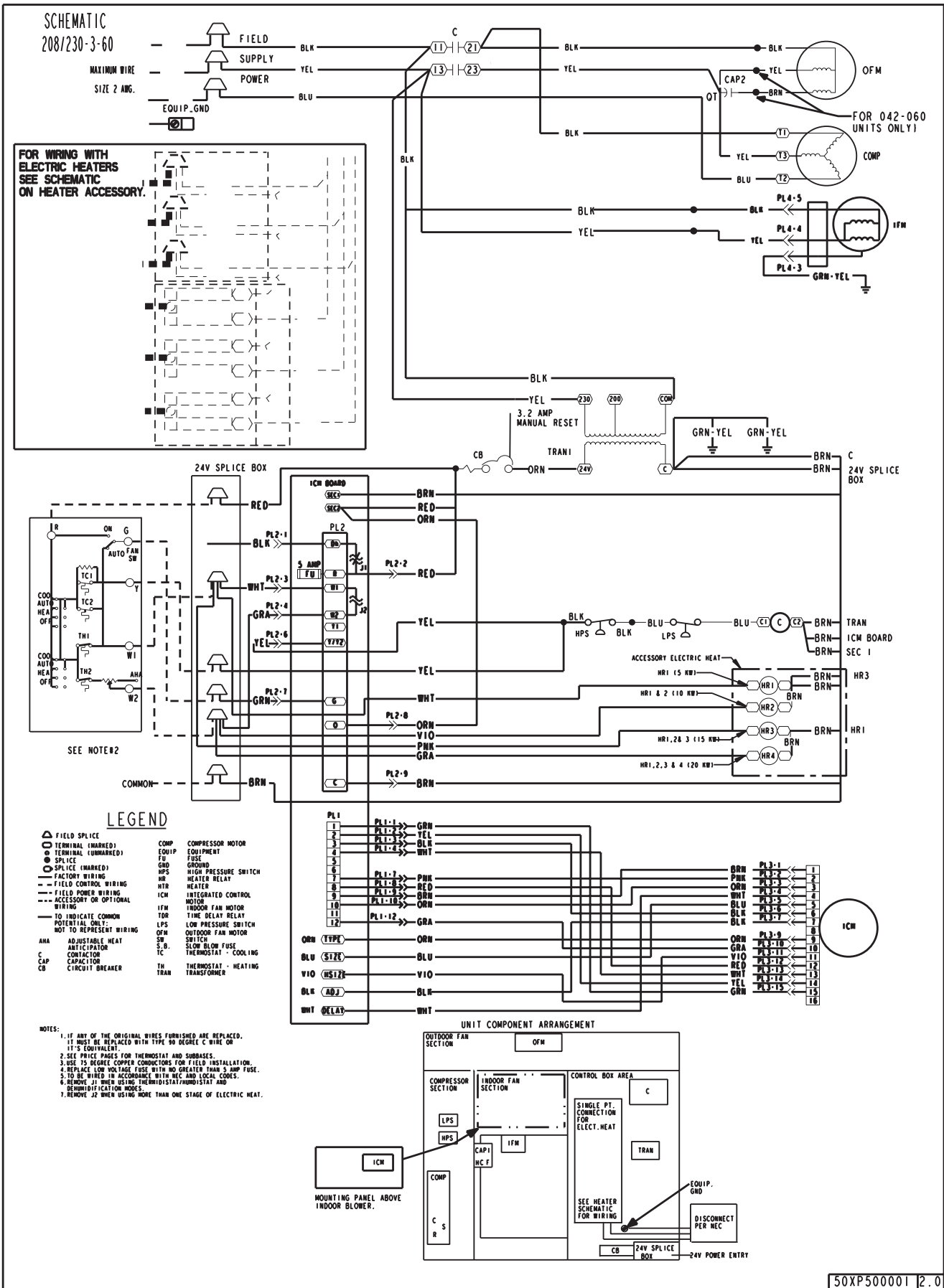

CONTROLS

SEQUENCE OF OPERATION

Cooling — When the system thermostat calls for cooling, 24 V is supplied to the “Y” and “G” terminals of the thermostat. This completes the circuit to the contactor coil (C) and indoor (evaporator) fan time delay relay (TDR). The normally open contacts of C close and complete the circuit to compressor motor (COMP) and to outdoor (condenser) fan motor (OFM). Both motors start instantly. The set of normally open contacts of TDR close and complete the circuit through IFM. The IFM starts according to the selection pin set-up on the Easy Select™ board.

On the loss of the thermostat call for cooling, 24 v is removed from both the “Y” and “G” terminals (provided the fan switch is in the “AUTO” position) deenergizing the compressor contactor and opening the contacts supplying power to compressor/OFM. After a pre-selected delay, the IFM shuts off. If the thermostat fan selector switch is in the “ON” position, the IFM will run continuously at speed selected on Easy Select™ board.

Heating — If accessory electric heaters are installed, on a call for heat, circuit R-W is made through the thermostat contacts. Circuit R-G is made which energizes the TDR. If the heaters are staged, then the thermostat closes a second set of contacts (W2) when second stage is required. When thermostat is satisfied, contacts open, deenergizing the heater relay and the TDR. After a pre-selected delay, the IFM shuts off. If the thermostat fan selector switch is in the “ON” position, the IFM will run continuously at speed selected on Easy Select™ board.

NOTE: On units with a Time Guard® II device: once the compressor has started and then stopped, it cannot be restarted again until 5 minutes have elapsed.

The indoor blower operation with a call for fan operation (G) in cooling mode will perform by the on/off delay profile selected at start up on the Easy Select™ board.

GUIDE SPECIFICATIONS

PACKAGED ELECTRIC COOLING UNITS CONSTANT VOLUME APPLICATION

HVAC Guide Specifications

Size Range: 2 to 5 Tons, Nominal Cooling

Bryant Model Number: 704B

Part 1—General

SYSTEM DESCRIPTION

Outdoor rooftop or ground mounted, electric cooling unit utilizing a hermetic compressor for cooling duty and optional electric heating. Unit shall discharge supply air vertically or horizontally as shown on contract drawings. Condenser fan/coil section shall have a draw-thru design with vertical discharge for minimum sound levels.

QUALITY ASSURANCE

- A. Unit shall be rated in accordance with ARI Standards 210/240-94 and 270-95.
- B. Unit shall be designed in accordance with UL Standard 1995.
- C. Unit shall be manufactured in a facility registered to ISO 9001 manufacturing quality standard.
- D. Unit shall be UL listed and c-UL certified as a total package for safety requirements.
- E. Roof curb shall be designed to conform to NRCA Standards.
- F. Insulation and adhesives shall meet NFPA 90A requirements for flame spread and smoke generation.
- G. Cabinet insulation shall meet ASHRAE Standard 62P.

DELIVERY, STORAGE AND HANDLING

Unit shall be stored and handled per manufacturer's recommendations.

Part 2 — Products

EQUIPMENT

- A. General:

Factory-assembled, single-piece, cooling unit. Contained within the enclosure shall be all factory wiring, piping, controls, refrigerant charge (R-410A), and special features required prior to field start-up.
- B. Unit Cabinet:
 1. Unit cabinet shall be constructed of phosphated, zinc-coated, pre-painted steel capable of withstanding 500 hours of salt spray.
 2. Normal service shall be through a single removable cabinet panel.
 3. The unit shall be constructed on a rust proof basepan that has an externally trapped, integrated sloped drain pan.
 4. Evaporator fan compartment top surface shall be insulated with a minimum 1/2-in. thick, flexible fiberglass insulation, coated on the air side and retained by adhesive and mechanical means. The evaporator wall sections will be insulated with a minimum semi-rigid foil-faced board capable of being wiped clean. Aluminum foil-faced fiberglass insulation shall be used in the entire indoor air cavity section.
 5. Unit shall have a field-supplied condensate trap.
- C. Fans:
 1. The evaporator fan shall be direct-drive variable speed motor and control, as shown on equipment drawings.
 2. Fan wheel shall be made from steel, and shall be double-inlet type with forward curved blades with corrosion resistant finish. Fan wheel shall be dynamically balanced.
 3. Condenser fan shall be direct drive propeller type with aluminum blades riveted to corrosion resistant steel spiders, be dynamically balanced, and discharge air vertically.
- D. Compressor:
 1. Fully hermetic compressors with factory-installed vibration isolation.
 2. Scroll compressors shall be standard on all units.
- E. Coils:

Evaporator and condenser coils shall have aluminum plate fins mechanically bonded to seamless copper tubes with all joints brazed. (Copper/copper and vinyl-coated construction available as option.) Tube sheet openings shall be belled to prevent tube wear.
- F. Refrigerant Metering Device:

Refrigerant metering device shall be of the TXV type.
- G. Filters:

Filter section shall consist of field-installed, throwaway, 1-in. thick fiberglass filters of commercially available sizes.
- H. Controls and Safeties:
 1. Unit controls shall be complete with a self-contained low voltage control circuit.
 2. Units shall incorporate an internal compressor protector that provides reset capability.
 3. Unit shall provide High and Low/Loss-of-Charge Pressure Safety Protection.
- I. Operating Characteristics:
 1. Unit shall be capable of starting and running at 125°F ambient outdoor temperature, exceeding maximum load criteria of ARI Standard 210.
 2. Compressor with standard controls shall be capable of operation down to 55° F ambient outdoor temperature.
 3. Fan on/off delay profile is selected (for cooling) on the Easy Select™ Board.
- J. Electrical Requirements:

All unit power wiring shall enter the unit cabinet at a single location.
- K. Motors:
 1. Compressor motors shall be of the refrigerant-cooled type with line-break thermal and current overload protection.
 2. All fan motors shall have permanently lubricated bearings, and inherent, automatic reset, thermal overload protection.
 3. Condenser fan motor shall be totally enclosed.
- L. Grille:
 1. Louvered Grille:

Louvered grille shall be standard on all units.
- M. Special Features Available
 1. Coil Options:

Shall include factory-installed optional tin-plated indoor, copper/copper and vinyl-coated refrigerant coils.
 2. Economizer:
 - a. Economizer controls capable of providing free cooling using outside air.
 - b. Equipped with low leakage dampers not to exceed 3% leakage, at 1.0 in. wg pressure differential.

GUIDE SPECIFICATIONS continued

- c. Spring return motor shuts off outdoor damper on power failure.
3. Flat Roof Curb:
Curbs shall have seal strip and a wood nailer for flashing and shall be installed per manufacturer's instructions.
4. Manual Outdoor Air Damper:
Package shall consist of damper, birdscreen, and rainhood which can be preset to admit outdoor air for year-round ventilation.
5. Thermostat:
To provide for one-stage heating and cooling in addition manual or automatic changeover and indoor fan control.
6. Low Ambient Package:
Shall consist of a solid-state control and condenser coil temperature sensor for controlling condenser-fan motor operation, which shall allow unit to operate down to 0° F outdoor ambient temperature.
7. Filter Rack Kit:
Shall provide filter mounting for downflow or horizontal applications.
8. Square-To-Round Duct Transitions:
Shall have the ability to convert the supply and return openings from rectangular to round. (024-048 only)
9. Compressor Protection (Time Guard® II Kit)
Solid-state control shall protect compressor by preventing "short cycling."
10. Crankcase Heater:
Shall provide anti-floodback protection for low-load cooling applications.
11. Electric heaters:
 - a. Electric heater shall be available as a field-installed option.
 - b. Heater elements shall be open wire type, adequately supported and insulated with ceramic bushings.
 - c. Electric heater packages must provide single point power connection capability.
12. Compressor Hard Start Kit:
Shall be available to give a boost to the compressor motor at each start-up. (Single Phase only).

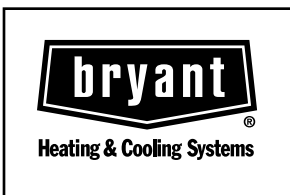

SPECIFICATIONS SUBJECT TO CHANGE WITHOUT NOTICE

UNIT MUST BE INSTALLED IN ACCORDANCE
WITH INSTALLATION INSTRUCTIONS

Cancels: PDS 704B.24.2

Form: PDS 704B.24.3